

ISSUE	DESCRIPTION	DATE

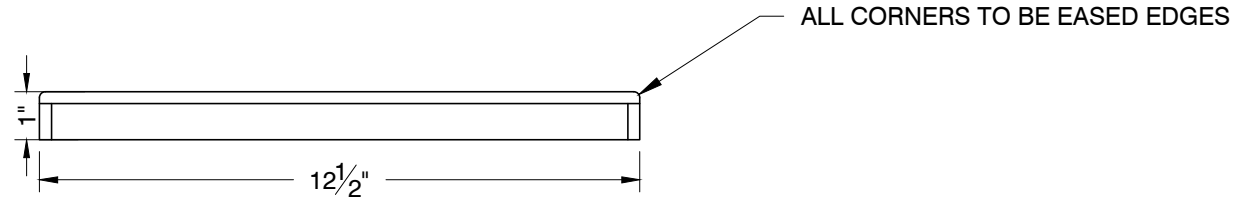

**1 ELEVATION**  
PART LID SCALE 1:4

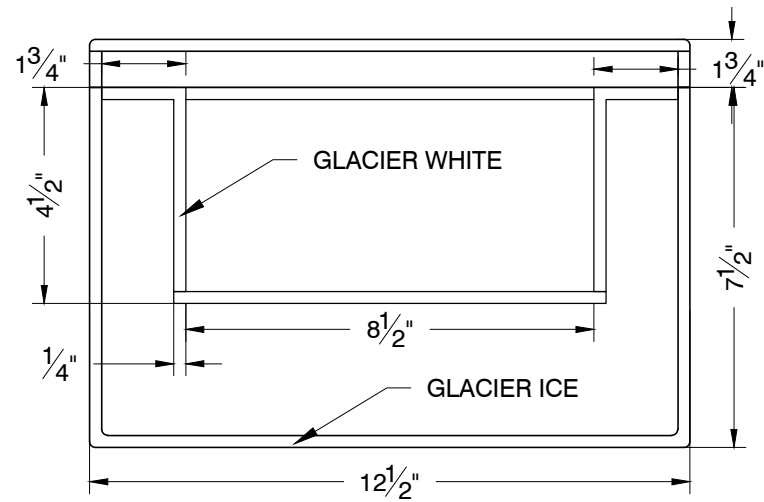

**2 SECTION**  
PART BOX & INNER TRAY SCALE 1:4

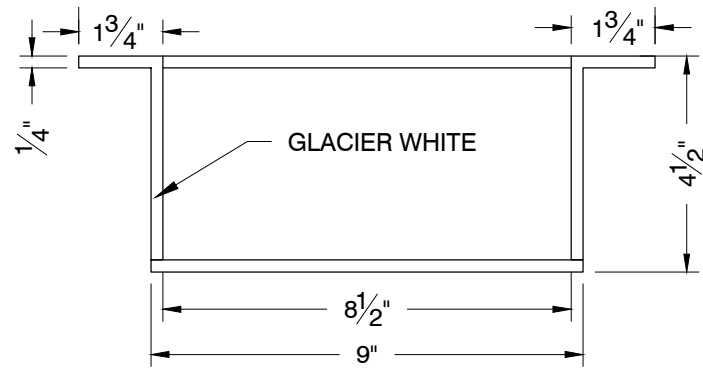

**4 SECTION**  
PART INNER TRAY SCALE 1:4

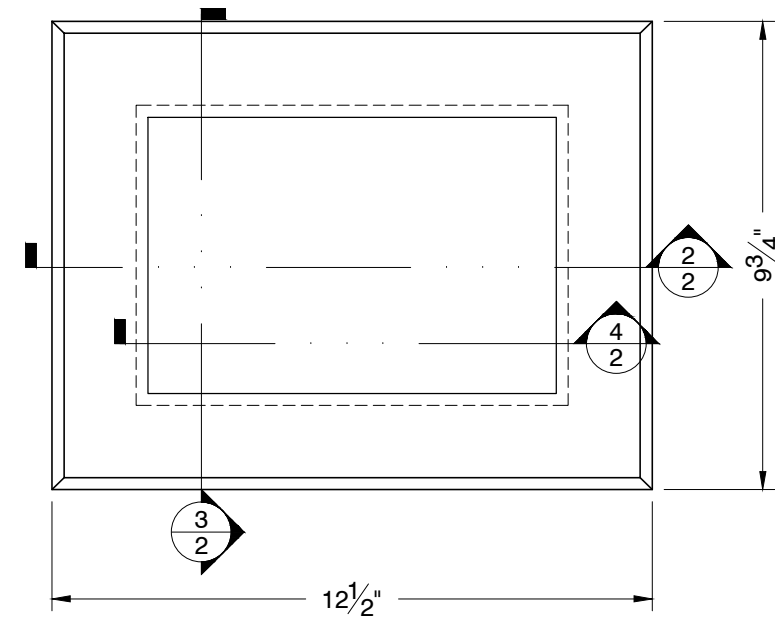

**5 PLAN**  
PART BOX & INNER TRAY SCALE 1:4

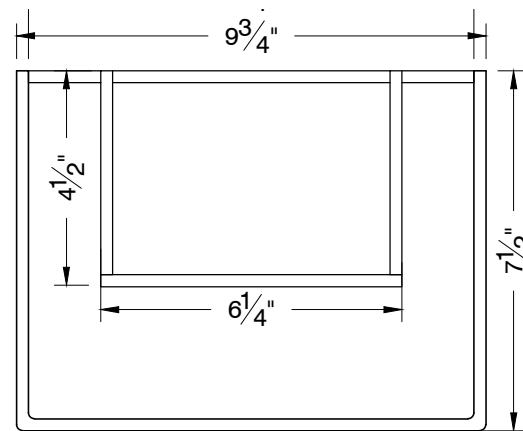

**3 SECTION**  
PART BOX & INNER TRAY SCALE 1:4

**Evans & Paul**  
140 DUPONT STREET, PLAINVIEW, NY 11803  
PHONE: 516 576 0800 FAX: 516 576 0806  
WWW.EVANSANDPAUL.COM

THIS DRAWING INCLUDING THE SPECIFICATIONS, CONCEPTS, DESIGNS AND ARRANGEMENTS REPRESENTED THERE BY OR INCORPORATED IN IT, IS AND SHALL REMAIN THE PROPERTY OF EVANS AND PAUL, LLC. IT SHALL BE USED ONLY FOR THE SPECIFIC PROJECT FOR WHICH IT HAS BEEN PREPARED. WITHOUT THE PRIOR WRITTEN AUTHORIZATION OF EVANS AND PAUL, LLC, IT SHALL NOT BE COPIED, DISCLOSED TO THIRD PARTIES, USED TO PERFORM OR COMPLETE THIS PROJECT BY OTHERS, OR USED IN CONNECTION WITH ANY WORK OR PROJECT OTHER THAN THE SPECIFIC PROJECT FOR WHICH IT HAS BEEN PREPARED. FOR ALL PROJECTS INSTALLED BY EVANS AND PAUL, LLC OR BY AN AGENT OF EVANS AND PAUL, LLC, FIELD DIMENSIONS MUST BE VERIFIED PRIOR RELEASE TO MANUFACTURE.

JOB NUMBER: 0014778 CUSTOMER PO# CLIENT PO  
CUSTOMER: EMILY WEBSTER  
PROJECT: ART BOX  
PHASE: AS NOTED COLOR: AS NOTED  
SHEET TITLE: SHEET TITLE SCALE: AS NOTED  
DRAWN BY: P.A.  
CHECKED BY: P.A.  
DATE: 05/23/2012

SHEET 1 OF 1

SIGNATURE OF APPROVAL: \_\_\_\_\_ DATE: \_\_\_\_\_  
THIS DRAWING IS RELEASED FOR CUSTOMER APPROVAL ONLY. THE INFORMATION CONTAINED HEREIN REMAINS NOT FOR MANUFACTURE PENDING FINAL REVIEW AND APPROVAL BY CUSTOMER.

**NOT FOR MANUFACTURE**